

Year 11 Physics

Test Questions Motion 1
Questions

Q1

- A man going for a hike along a bush trail walks 12 km east, then turns around and heads back home, walking 3 km west, before stopping to have a rest. State the distance covered by the man, and his displacement, when he stops to have his rest.

Distance covered =

Displacement = .

Q2

A flea jump results in one of the most impressive examples of acceleration in the animal kingdom. By pushing its legs against the ground, the flea can attain an initial upward velocity of 1.00 m/s in a time of 1.00 millisecond.

- (a) What is the flea's average acceleration when pushing off the ground? [1 mark]

Q2 continued

(b) Calculate how high the flea manages to jump off the ground.

[3 marks]

Q3

A cyclist accelerates from rest on a smooth horizontal road. The graph below shows how the force applied to the bicycle by the cyclist changed over this period of acceleration.

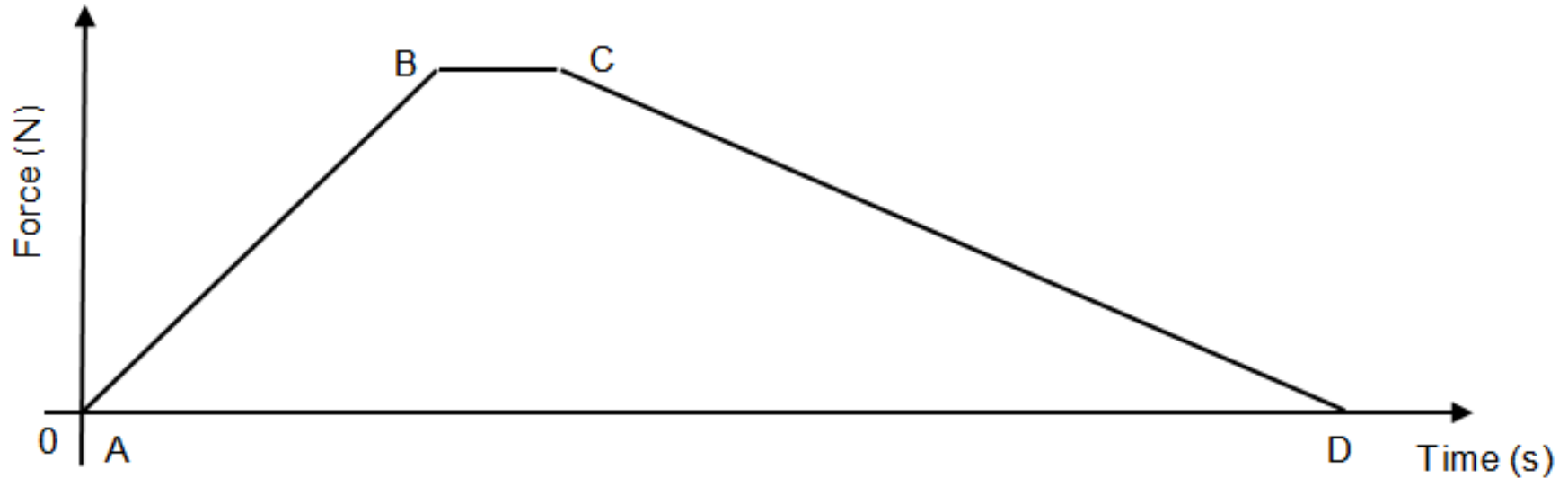

- (a) During which stage of the motion as represented in the graph was the acceleration of the cyclist greatest? (Circle your choice) [2 marks]

AB

BC

CD

Q3 continued

- (b) The change in momentum of the cyclist can be calculated by finding which of the following quantities? (Circle your choice) [3 marks]

the gradient of AB

the average gradient from A to D

the area under the graph

Explain your answer:

Q4

- A steel bolt of mass 150 g is fired from a crossbow at a rolling wooden target that is moving toward the crossbow. The crossbow bolt is moving at 24.0 m s^{-1} East. The rolling target has a mass of 5.00 kg and is moving at 1.40 m s^{-1} West. On impact the crossbow bolt becomes embedded into the target. Calculate the velocity of the target and embedded bolt after the collision.

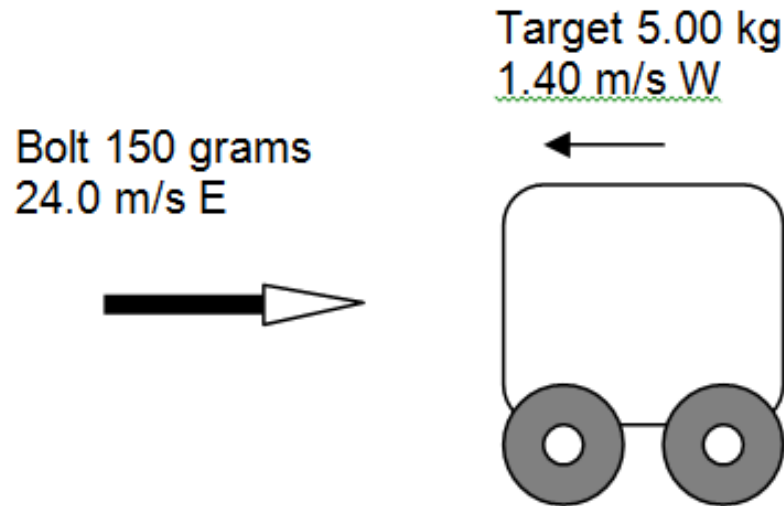

Q5

- A rocket of mass 10 tonnes (including fuel) is in deep space where the effects of gravity from any other objects can be ignored. When it starts to burn fuel there is a constant thrust force from its engines. *Refer to Newton's laws of motion in your answers to this question.*
- Explain how the burning of fuel to make exhaust gas exit from the back of the jet cones can accelerate the rocket forwards.

Q5 continued

- Explain what happens to the magnitude of acceleration as the rocket is burning fuel.
- The rocket burns 2 tonnes of fuel to accelerate to 1500 m s^{-1} over a distance of 100 km. How much fuel would be needed to continue forwards at a constant velocity of 1500 m s^{-1} for a distance of 2,000 km? Explain briefly.(no calculation required)

Q6

- The graph shows the velocity of a toy car over a 20 second period. The car can only move back and forth along a straight line. East of the start point is considered positive.

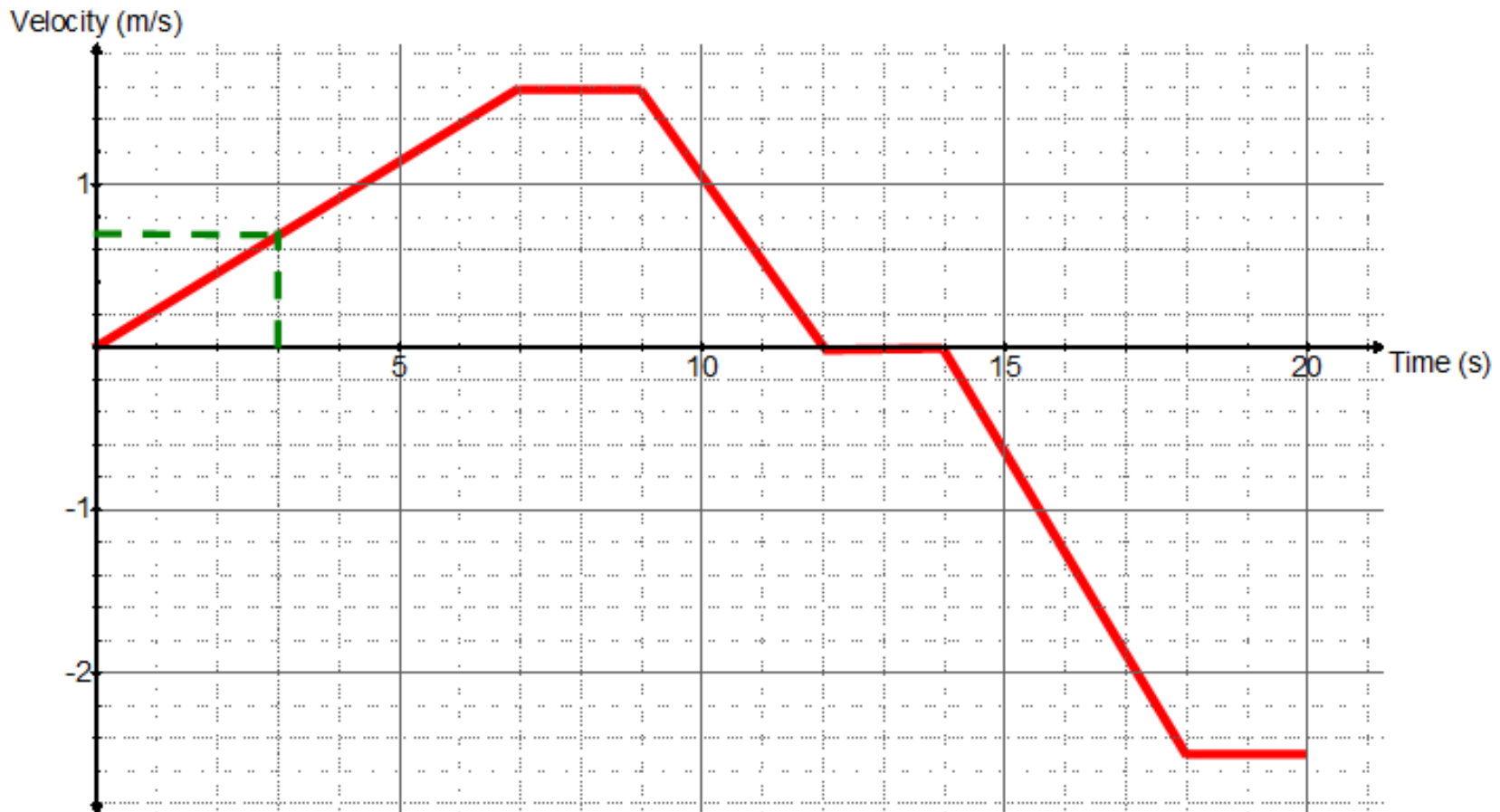

Q6 continued

- From the graph, determine the velocity of the car after 3 seconds of travel.
- For how many seconds was the car stationary?
- At a time of 10 seconds, explain whether the car was moving towards or away from the initial position.

Q6 continued

- Between which two times was the magnitude of acceleration the greatest?
- From your graph, determine the acceleration at 16 seconds.

Q6 continued

- Determine the displacement of the car after 20 seconds.

Q7

A hunter leans over the edge of a cliff and fires a crossbow bolt vertically upwards with an initial velocity of 38.6 m s^{-1} .

The bottom of the cliff is 29.1 m below the point where the bolt left the crossbow.

Calculate the maximum height reached by the bolt above the launch height of the hunter. (3)

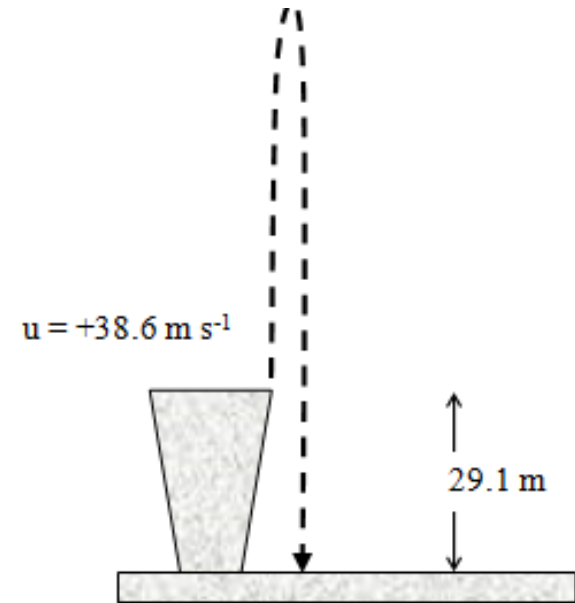

Q7 continued

- Determine the acceleration of the bolt at its maximum height

Q7 continued

- Calculate the velocity of the bolt 5.00 seconds after leaving the crossbow.

Q7 continued

- Calculate the total time the bolt was in flight from leaving the crossbow to arriving at the bottom of the cliff.

Q7 continued

- Calculate the average velocity of the bolt from leaving the crossbow to arriving at the bottom of the cliff.

Q8

- Diagram below shows a gymnast trampolining.

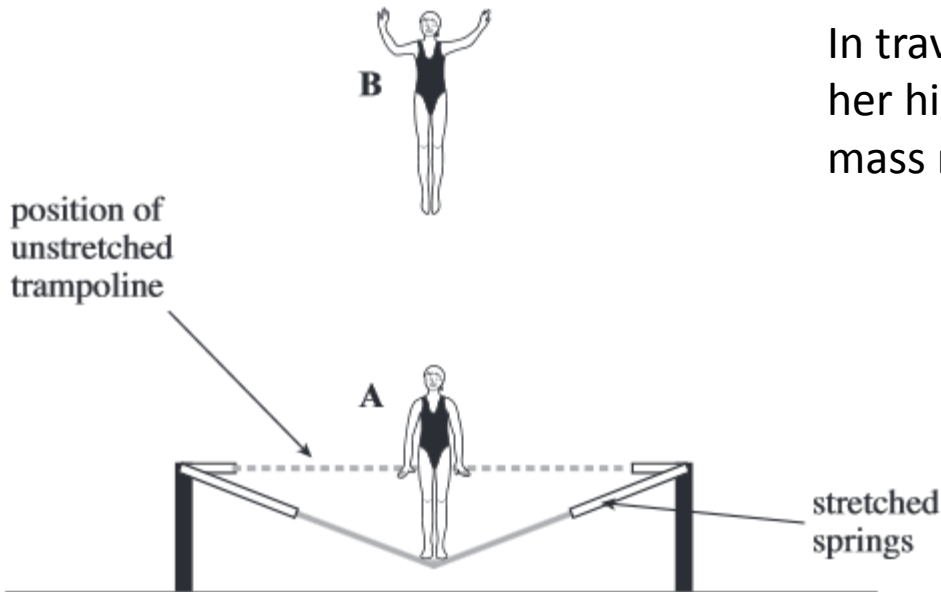

In travelling from her lowest position at A to her highest position at B, her centre of mass rises 4.2m vertically. Her mass is 55kg.

- (a) Calculate the increase in her gravitational potential energy when she ascends from position A to position B.

Q8 continued

- (b) The gymnast descends from position B and regains contact with the trampoline when it is in its unstretched position. At this position, her centre of mass is 3.2 m below its position at B
- (b) (i) Calculate her kinetic energy at the instant she touches the unstretched trampoline.
- (b) (ii) Calculate her vertical speed at the same instant.

Q8 continued

- As she accelerates upwards again from position A , she is in contact with the trampoline for a further 0.26s. Calculate the average acceleration she would experience while she is in contact with the trampoline, if she is to reach the same height as before.

Q9

- Diagram below shows a rollercoaster train that is being accelerated when it is pulled horizontally by a cable

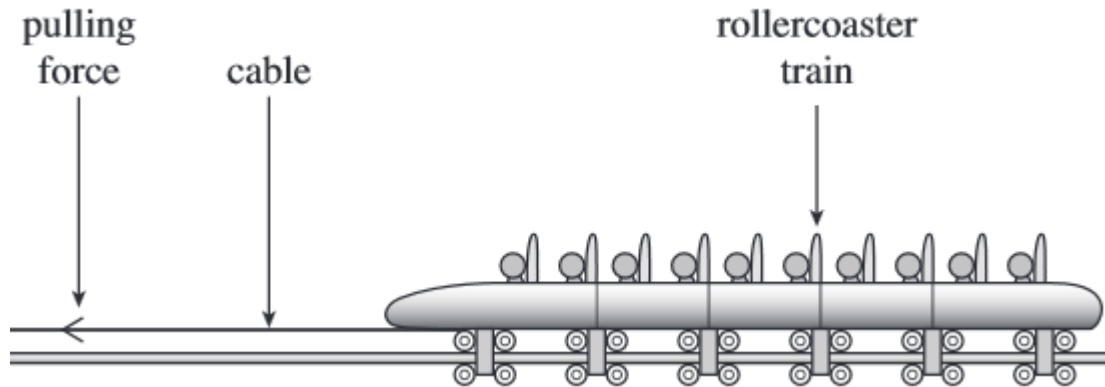

- (a)** The train accelerates from rest to a speed of 58 ms^{-1} in 3.5 s . The mass of the fully loaded train is 5800 kg .
- (a) (i)** Calculate the average acceleration of the train.

Q9 continued

(a) (ii) Calculate the average tension in the cable as the train is accelerated, stating an appropriate unit.

(a) (iii) Calculate the distance the train moves while accelerating from rest to 58 ms^{-1}

Q10

- (a) (iv)** The efficiency of the rollercoaster acceleration system is 20% .
Calculate the average power input to this system during the acceleration.

Q11

- An 'E-bike' is a bicycle that is assisted by an electric motor. The diagram below shows an E-bike and rider with a total mass of 83kg moving up an incline.

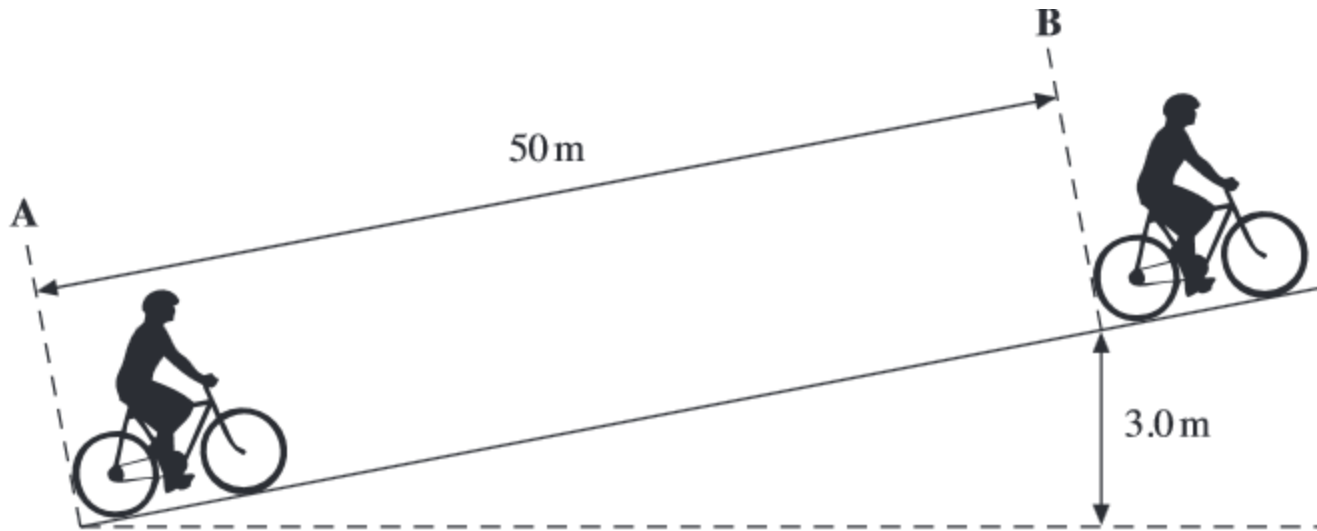

Q11 continued

- (a) (i) The cyclist begins at rest at A and accelerates uniformly to a speed of 6.7 m s^{-1} at B. The distance between A and B is 50m. Calculate the time taken for the cyclist to travel this distance

Q11 continued

- (a) (ii) Calculate the kinetic energy of the E-bike and rider when at B.

(a) (iii) Calculate the gravitational potential energy gained by the E-bike and rider between A and B.

Q11 continued

- (b)** Between **A** and **B**, the work done by the electric motor is 3700 J, and the work done by the cyclist pedalling is 5300 J.
- (b) (i)** Calculate the wasted energy as the cyclist travels from **A** to **B**.

Q12

The world record for a high dive into deep water is 54 m.

- (a) Calculate the loss in gravitational potential energy (gpe) of a diver of mass 65 kg falling through 54 m.

Calculate the time taken for the diver to fall 54 m. Ignore the effects of air resistance.