

Physics: Contact Forces and Tension

Box / Tension Problem



- A force is applied to a box that is connected to other boxes by ropes. The whole system is accelerating to the left.
- The problem is to find the tensions in the ropes.
- We can apply the 2nd Law to each box individually as well as to the whole system.

Box / Tension Analysis



- T_1 pulls on the 8-kg box to the right just as hard as it pulls on the middle box to the left.
- T_1 must be < 38 N, or the 8-kg box couldn't accelerate.
- T_2 pulls on the middle box to the right just as hard as it pulls on the 6-kg box to the left.
- T_1 must be $> T_2$ or the middle box couldn't accelerate.

Free Body Diagram – system

For convenience, we'll choose left to be the positive direction.

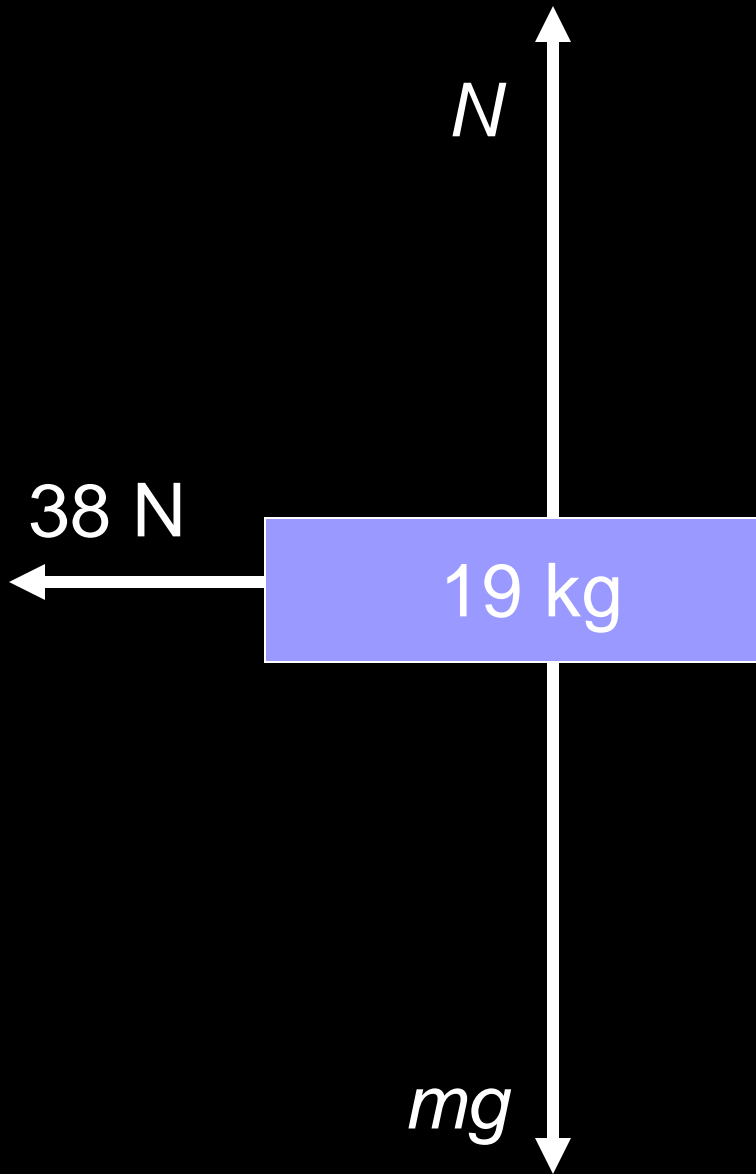

The total mass of all three boxes is 19 kg.

N and ***mg*** cancel out.

$$F_{net} = ma \text{ implies}$$
$$a = 2.0 \text{ m/s}^2$$

Since the ropes don't stretch, ***a*** will be 2.0 m/s² for all three boxes.

Free Body Diagram – right box

N and **mg** cancel out.

For this particular box,

$F_{net} = ma$ implies:

$$T_2 = 6a = 6(2) = 12 \text{ N.}$$

(Remember, $a = 2 \text{ m/s}^2$ for all three boxes.)

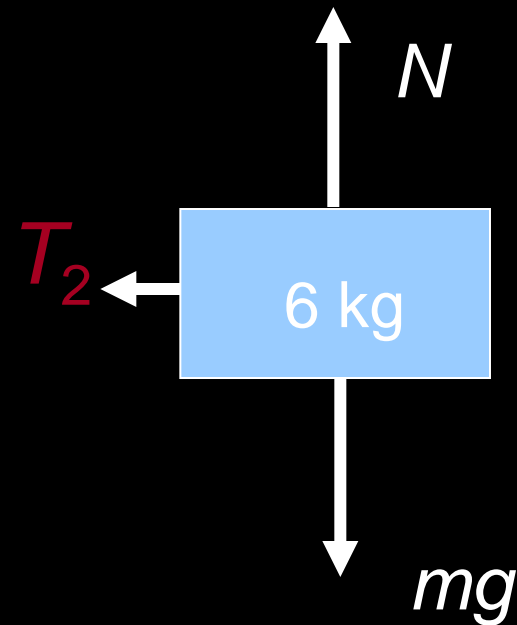

Free Body Diagram – middle box

N and mg cancel out again.

$F_{\text{net}} = ma$ implies:

$T_1 - T_2 = 5a$. So,

$T_1 - 12 = 5(2)$, and
 $T_1 = 22 \text{ N}$

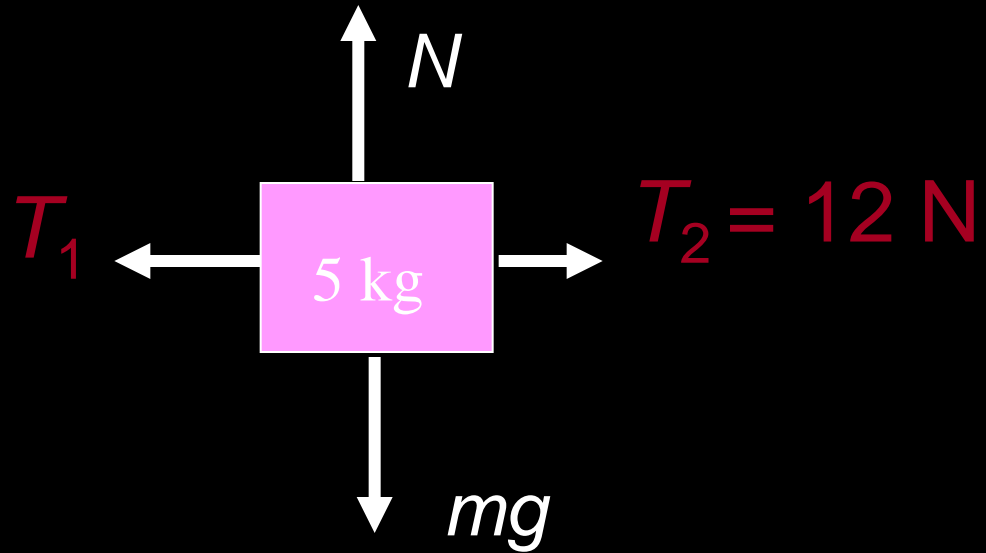

Free Body Diagram – left box

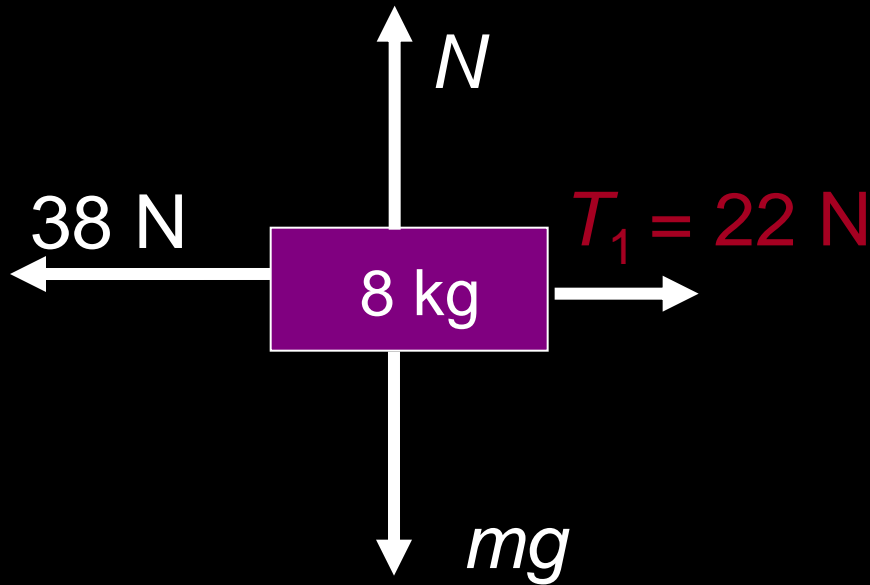

Let's check our work using the left box.

N and mg cancel out here too.

$F_{net} = ma$ implies:

$$38 - 22 = ma = 8(2).$$

$$16 = 16.$$

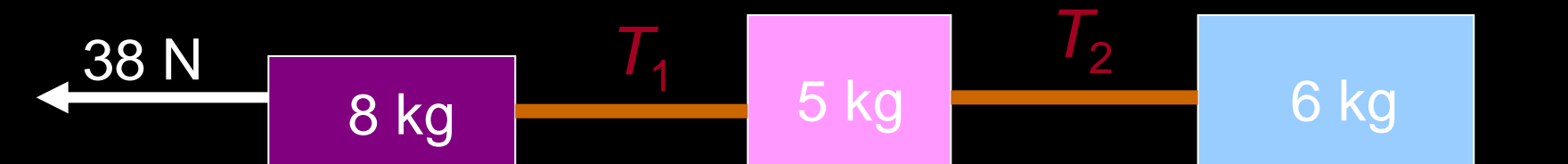



A car of mass 1750 kg pulls a caravan of mass 1250 kg along a straight, horizontal road. The car's engine force is 5025 N.

- (a) Calculate the acceleration of (i) the car and (ii) the caravan
(b) Calculate the tension in the tow bar between the car and caravan

(a)

$$a = \frac{F_{\text{net}}}{m}$$

$$= \frac{5025}{(1250 + 1750)}$$

$$= 1.68 \text{ ms}^{-2}$$



(b) Calculate the tension in the tow bar between the car and caravan

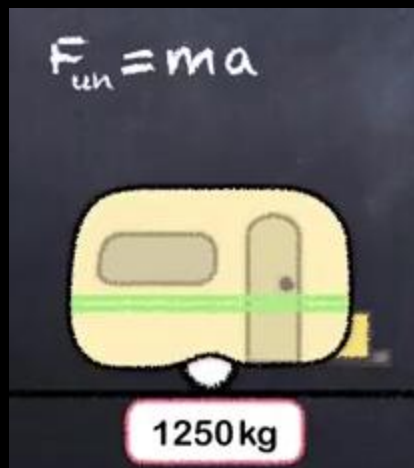

$$F_{\text{un}} = ma = 1250 \times 1.68 = 2100 \text{ N}$$



A car of mass 1750 kg pulls a caravan of mass 1250 kg along a straight, horizontal road. The car's engine force is 5025 N. The frictional force acting on the car is 755 N, with a frictional force of 670 N acting on the caravan.

- (a) Calculate the acceleration of (i) the car and (ii) the caravan
- (b) Calculate the tension in the tow bar between the car and caravan



(a)

$$F_{un} = 5025 + (-670) + (-755)$$

$$a = \frac{F_{un}}{m} = \frac{3600}{(1250 + 1750)} = 1.20 \text{ ms}^{-2}$$

(b)

$$F_{un} = ma$$

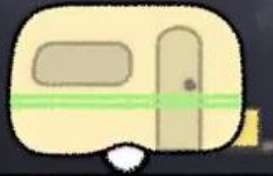

1250 kg



50 kg

1750 kg

(b)

$$F_{un} = ma = 1250 \times 1.20 = 1500 \text{ N}$$

$$F_{un} = \text{Tension} + \text{friction}$$

$$1500 = \text{Tension} - 670$$

$$\text{Tension} = 1500 + 670 = 2170 \text{ N}$$

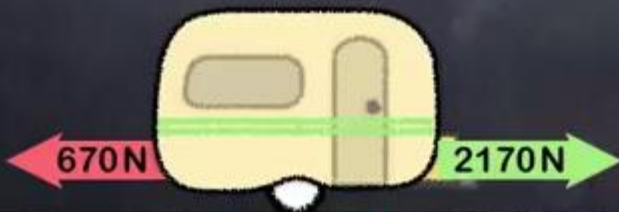

1250 kg



50 kg

1750 kg

A 900kg car is pulling a 200kg trailer. The car has an applied force of 3000N. The frictional forces are 1000N for the car and 500N for the trailer. Determine the force on the hitch.

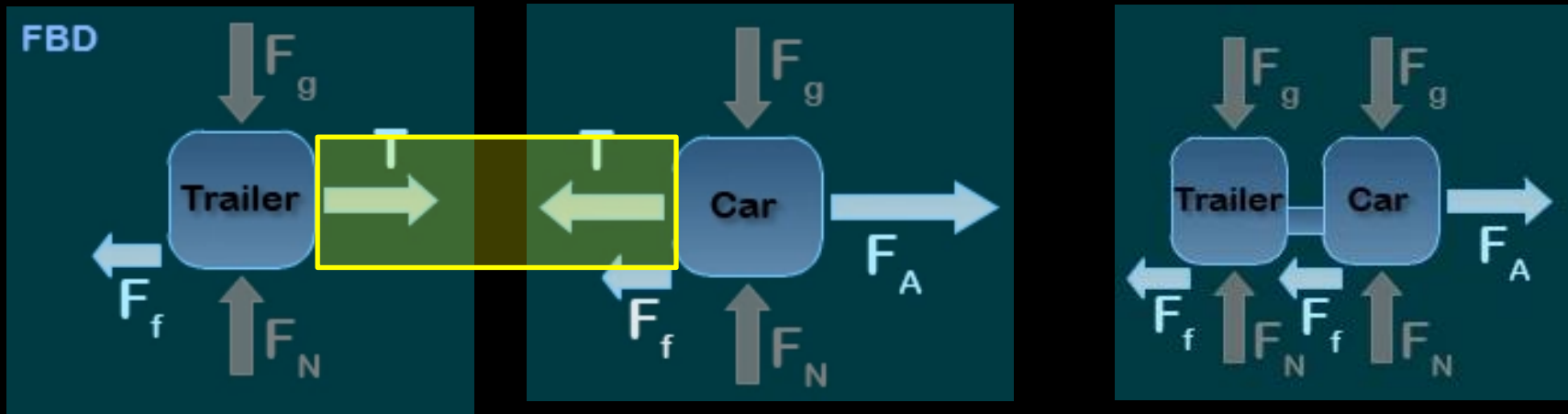

$$F_{\text{NET}} = ma$$

$$T - F_f = m_t a$$

$$F_{\text{NET}} = ma$$

$$F_A - T - F_f = m_c a$$

$$F_{\text{NET}} = ma$$

$$F_A - F_{fc} - F_{ft} = (m_c + m_t) a$$

$$a = \frac{F_A - F_{fc} - F_{ft}}{(m_c + m_t)} = 1.364 \text{ m/s}^2$$

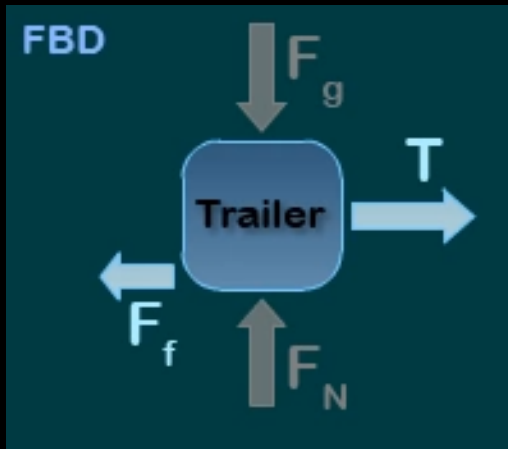

$$F_{NET} = ma$$

$$T - F_f = m_t a$$

$$T = m_t a + F_f = 773\text{N}$$

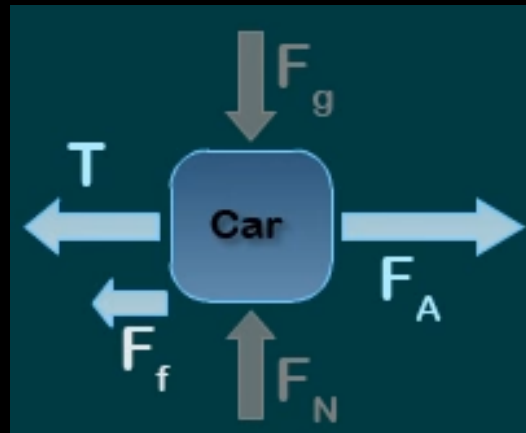

$$F_{NET} = ma$$

$$F_A - T - F_f = m_c a$$

$$T = F_A - m_c a - F_f = 772\text{N}$$

Car Trailer Example

Jack is going on a holiday in a yellow car (these always travel slower than red cars). Jack is trying to remember his physics from school.

What is his acceleration?

What is the tension force pulling forward on the trailer?

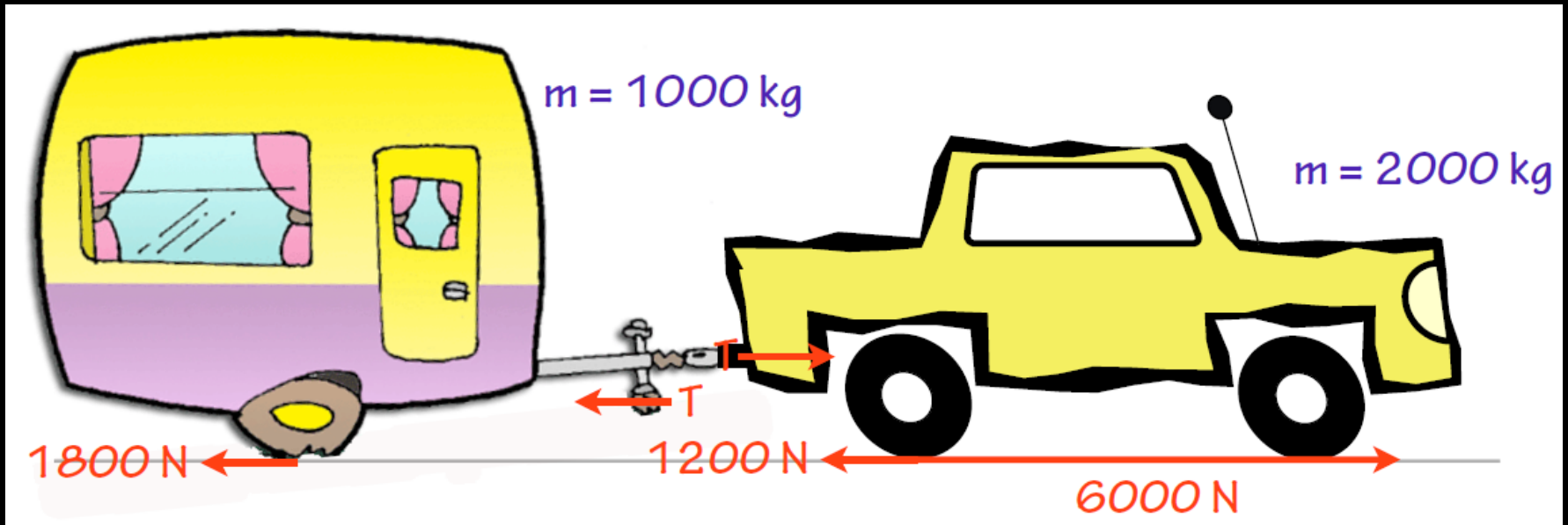

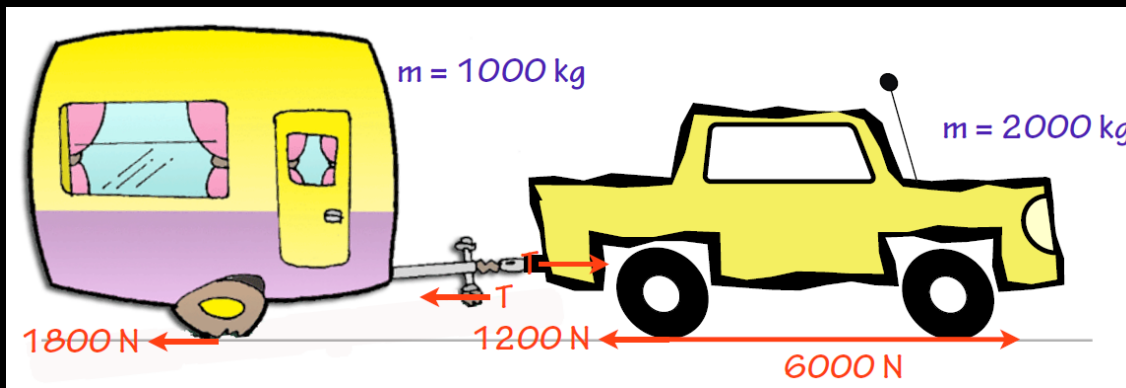

$$a = \frac{6000 \text{ N} - 3000 \text{ N}}{3000 \text{ kg}}$$

$$a = \frac{3000 \text{ N}}{3000 \text{ kg}}$$

$$a = 1.0 \text{ m/s}^2$$

Trailer:

$$\sum F = ma = 1000 \text{ kg} \times 1.0 \text{ m/s}^2$$

$$\sum F = 1000 \text{ N}$$

$$1000 \text{ N} = T - 1800 \text{ N}$$

$$T = 2800 \text{ N (forward)}$$

Car:

$$\sum F = ma = 2000 \text{ kg} \times 1.0 \text{ m/s}^2$$

$$\sum F = 2000 \text{ N}$$

$$2000 \text{ N} = 6000 \text{ N} - 1200 \text{ N} - T$$

$$T = 2800 \text{ N (back)}$$